

# **TCP 015**

---

# **TCP 035**

## **Electronic Drive Unit**

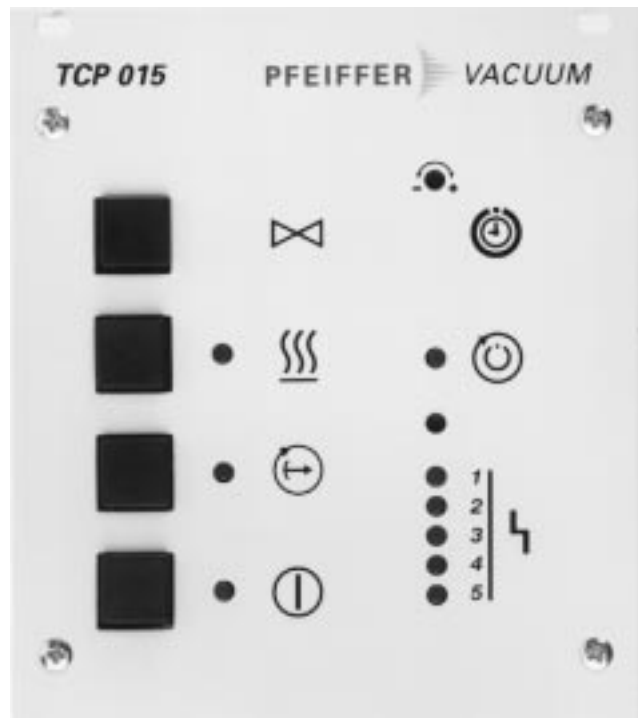

# Index

	Page		Page	
<b>TCP 015</b>	<b>1. Safety Instructions</b> .....	<b>3</b>	<b>6. Installation, TCP 035</b> .....	<b>11</b>
	<b>2. Understanding The Electronic Drive Unit TCP 015</b> .....	<b>4</b>	6.1. Preparations For Installation.....	11
	2.1. For Your Orientation.....	4	6.2. Fitting The Unit In A Rack .....	11
	2.2. Product Description.....	4	6.3. Connecting To The Mains.....	11
	Connection Options .....	4	6.4. Connecting The Turbopump.....	12
	Proper Use .....	4	6.5. Connecting The Remote Control Unit .....	12
	Improper Use .....	4	6.6. The Relay Output.....	12
	2.3. Description Of The Front Panel.....	5	6.7. Connecting The Backing Pump .....	12
	2.4. Description Of The Rear Panel .....	5	6.8. Connecting The Serial Interface .....	12
	<b>3. Installation, TCP 015</b> .....	<b>5</b>	<b>7. Operations, TCP 035</b> .....	<b>13</b>
	3.1. Preparations For Installation.....	5	7.1. Setting Various Operating Modes.....	13
	3.2. Fitting The Unit In A Rack .....	5	7.2. Switching ON The Electronic Drive Unit.....	13
3.3. Mains Power Connection .....	5	Self-Testing .....	13	
3.4. Connections Diagram .....	5	7.3. Starting Up The Turbopump .....	13	
3.5. Connecting The Turbopump.....	6	Normal Operations, Turbopump .....	13	
3.6. Connecting The Venting Valve.....	6	7.4. Switching "Stand-By" ON And OFF .....	13	
3.7. Connecting The Pumping Station Control Unit TCS 015 (optional).....	6	7.5. Operations With Motor Current Monitoring .....	13	
3.8. Connecting The Pump Heating Unit.....	7	7.6. Altering The Pre-Settings (S14) .....	14	
3.9. Connecting The Air Cooling Unit .....	7	7.7. Error Reset .....	14	
3.10. Connecting The Remote Control Unit .....	7	7.8. Switching The Turbopump ON and OFF .....	14	
3.11. Connecting The Backing Pump With Intermittent Operations.....	7	7.9. The Serial Interface .....	14	
3.12. Connecting The Serial Interface .....	7	<b>8. What To Do In The Case Of Breakdowns?</b> .....	<b>15</b>	
<b>4. Operations, TCP 015</b> .....	<b>8</b>	8.1. The Function Of The Illuminating Diodes .....	15	
4.1. Switching ON The Electronic Drive Unit And The Turbopump .....	8	8.2. Function Test In The Event Of A Malfunction.....	15	
Self-Testing.....	8	8.3. Eliminating Errors.....	15	
4.2. Switching "Stand-By" ON And OFF .....	8	8.4. Error Code Table .....	15	
4.3. Turbopump Venting .....	8	<b>9. Maintenance, Service</b> .....	<b>16</b>	
4.4. Switching The Heating Unit ON And OFF.....	8	<b>10. Technical Data</b> .....	<b>16</b>	
4.5. Operations Messages .....	8	12.1. Data List.....	16	
4.6. Use Of The Remote Control Unit.....	8	12.2. Dimensions Diagram .....	16	
4.7. Reset .....	9	<b>11. Connections Diagram</b> .....	<b>17</b>	
4.8. The Serial Interface .....	9	<b>12. Pin Arrangement</b> .....	<b>18</b>	
4.9. Operations With The Backing Pump.....	9	<b>13. Spare Parts</b> .....	<b>19</b>	
4.10. Operations with Pumping Station Control Unit TCS 015.....	9	<b>14. Accessories</b> .....	<b>19</b>	
4.11. Switching OFF.....	9	<b>Manufacturer's Declaration</b> .....	<b>Last page</b>	
<b>5. Understanding The Electronic Drive Unit TCP 035</b> .....	<b>10</b>			
5.1. Product Description.....	10			
Connection Options .....	10			
Proper Use .....	10			
Improper Use .....	10			
<b>TCP 035</b>				

# 1. Safety Precautions

---

- ☞ Read and follow all the instructions in this manual.  
Inform yourself regarding:
  - Hazards which can be caused by the unit,
  - Hazards which can arise in your system,
- ☞ Comply with all safety and accident prevention regulations.
- ☞ Check regularly that all safety requirements are being complied with.
- ☞ Take account of the ambient conditions when installing the TCP 015. The protection type is IP20. The unit is protected against the ingress of foreign bodies  $\geq \varnothing 12\text{mm}$ . Because water protection is not provided the unit must be fitted into a suitable housing (please see Section 3. Installation).
- ☞ Disconnect the plug connector on the TCP or pump only once the mains plug has been disconnected and the pump is at rest.
- ☞ When connecting the plug make sure that all mechanical locking devices are in place.
- ☞ After connecting the mains cable check for safe PE connection to the housing.
- ☞ Do not open the housing cover when the unit is connected to the mains nor during pumping operation.
- ☞ Do not carry out any unauthorised conversions or modifications on the unit.
- ☞ When returning the unit to us please note the shipping instructions (please see Section 7.).

## Pictogram Definitions



Danger of an electric shock from touching the contacts.



Danger of personal injury.



Danger of damage to the unit or system.

Modifications reserved.

## 2. Understanding The Electronic Drive Unit TCP 015

### 2.1. For Your Orientation

#### Symbol Used

The following symbols are used throughout in the illustrations:

- Ⓜ High vacuum flange
- Ⓥ Fore-vacuum flange
- Ⓧ Venting connection
- Ⓝ Cooling water connection
- Ⓛ Electric connection
- Ⓚ Air cooling

#### Position Numbers

Identical pump and accessory parts have the same position numbers in all illustrations.

#### In The Text

➔ Operating instruction: Here, you have to do something.

### 2.2. Product Description

The Electronic Drive Unit TCP 015 serves to drive PFEIFFER turbomolecular pumps with single phase direct current motors (1500 Hz). With the aid of a transformer the mains voltage is reduced to 32 V, rectified and provides the drive energy for the Print Module TCP 035 which is an element of the TCP 015. The switchable transformer power pack covers the following input voltage ranges:

- 90-112 V
- 108-133 V
- 198-245 V
- 216-267 V AC.

The TCP can be operated in conjunction with Pumping Station Control Unit TCS 015 to operate a pumping station with backing pump.

The delivery consignment encompasses:

- Electronic Drive Unit TCP 015
- Mating plug for X1, X2, X3.

The TCP 015 has been suppressed in accordance with German Industrial Standard VDE 0871, limit value curve B. The unit has been tested and cleared by the appropriate authorities in accordance with EN 61010/VDE0411 "Safety Ordinance For Electrical Units".

The electronic drive unit contains the following functional features:

- Switching power pack
- Motor drive
- Monitoring and process control
- Illuminating diode display with information concerning the operational status of the pump
- Serial Interface RS 232/ RS 485 on the Print Module of the TCP 035

#### Connection Options For:

- Remote control,
- Pumping Station Control Unit TCS 015 with connection options for the backing pump and fore-vacuum safety valve,
- Host computer via Serial Interface RS 485/RS 232,
- Heating for the turbomolecular pump,
- Air cooling for the turbomolecular pump.

#### Proper Use:

- The Electronic Drive Unit TCP 015 may only be used to drive and monitor PFEIFFER turbomolecular pumps.
- The operations unit TCP- turbopump may only be operated together with a backing pump.
- Pumping Station Control Unit TCS 015 is necessary for controlling the backing pump and fore-vacuum safety valve.
- Instructions concerning installation, start-up, operating and maintenance must be observed.

#### Improper Use:

Improper is:

- Uses not covered above, and, in particular,
  - Connection to pumps and units which is not permitted in their operating instructions.
  - Connection to pumps and units which is not permitted in their operating instructions.

Improper use will cause any rights regarding liability and guarantees to be forfeited.

### 2.3. Description Of The Front Panel

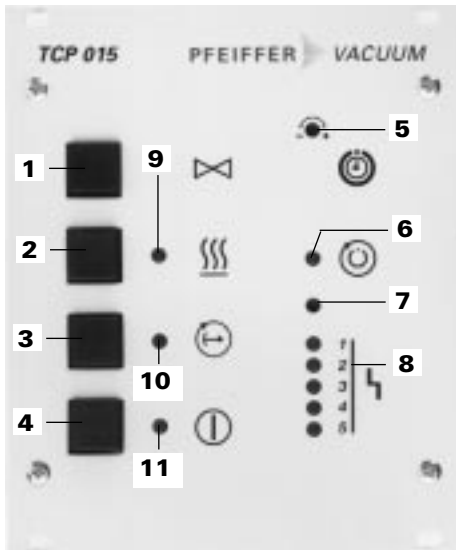

- |    |       |   |
|----|-------|---|
| 1  | S16   | Venting ON/OFF                          |
| 2  | S2    | Heating ON/OFF                          |
| 3  | S9    | Stand-by ON/OFF                         |
| 4  | S1    | Mains ON/OFF                            |
| 5  | R52   | Potentiometer start time                |
| 6  | H6    | LED rotation speed switchpoint attained |
| 7  | R53   | Potentiometer current switchpoint       |
| 8  | H1    | LED collective error message            |
|    | H2-H5 | LEDs error coding                       |
| 9  | H7    | LED heating ON                          |
| 10 | H8    | LED stand-by ON                         |
| 11 | H7    | LED mains ON                            |

### 2.4. Description Of The Rear Panel

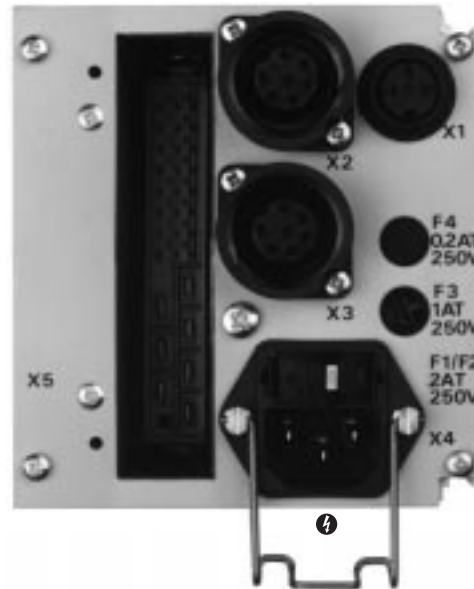

- |    |                                 |
|----|---------------------------------|
| X1 | Connector socket, venting valve |
| X2 | Connector socket, air cooling   |
| X3 | Connector socket, pump heating  |
| X4 | Connector socket, mains         |
| X5 | Connector socket, pump          |
| F1 | Mains fuse                      |
| F2 | Mains fuse                      |
| F3 | Pump heating/air cooling fuse   |
| F4 | Venting valve fuse              |

## 3. Installation, TCP 015

### 3.1. Preparations For Installation



Unauthorised modifications or alterations to the electronic drive unit are not allowed. The unit must be fitted in a housing taking account of the ambient conditions (see Section 9., "Technical Data").

Please refer to Section 13. for the electrical connections diagram.

➔ Disconnect mains power before installation work.

### 3.2. Fitting The Unit Into A Rack

The Electronic Drive Unit TCP 015 is a 3/12-19", 3 HE insert module designed to be fitted into a 19"/3HE rack. The following should be taken account of when fitting:

The ambient temperature in the rack casing should not exceed 40 °C and other insert modules should not restrict the circulation of air.

### 3.3. Mains Power Connection

- The unit has been designated protection class 1 and must therefore always be connected with the earthed conductor (PE).
- Mains connection must be made in accordance with the local regulations.



Danger of an electrical shock resulting from incorrect connections.

- ➔ Before connecting the unit check the mains voltage on the selection switch. If changes in the settings are necessary:
- ➔ Unlock the fuse drawer with the help of a small screwdriver, remove the grey fuse box and re-insert so that the correct voltage range (please see Section 2.2.) appears in the drawer window.
- ➔ Insert drawer, connect mains power cable and secure with locking guard.
- ➔ If Pumping Station Control Unit TCS 015 is to be operated make the mains power connection via TCS/X8.

The fuses shown in the following table can be replaced if the mains power plug is disconnected:

Designation	Current Circuit	Type
F1	Primary side	2 AT
	Mains transformer	
F2	Incoming mains power line	1 AT
F3	Heating, air cooling	1 AT
F4	Venting valve	0,2 AT

### 3.4. Connections Diagram

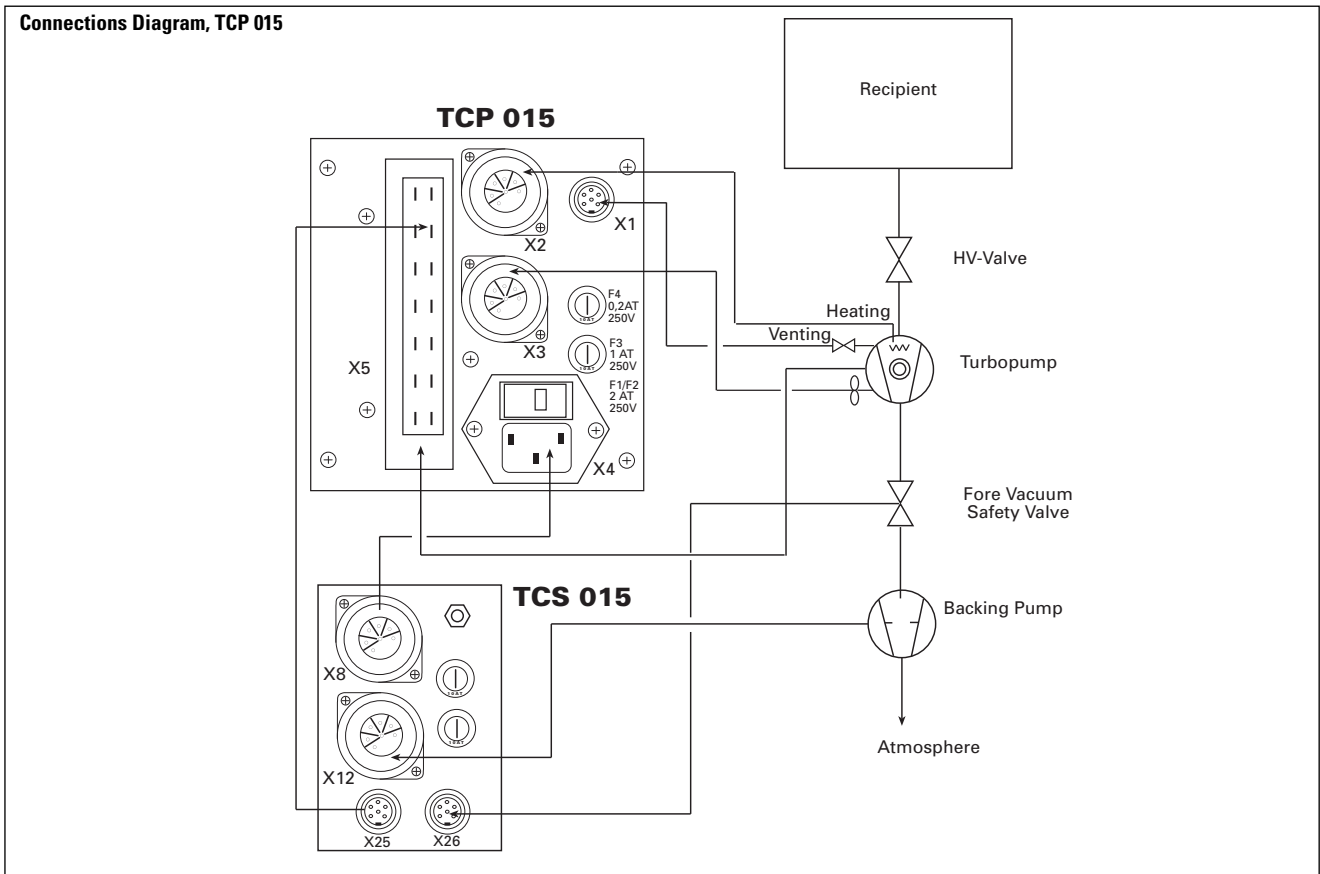

### 3.5. Connecting The Turbopump



Only disconnect the plug connector to the electronic drive unit once the pump is completely at rest and the electronic drive unit has been disconnected from the mains power supply.

- ➔ Connect the turbomolecular pump with connecting cable to connector socket X5 as per the connections diagram in Section 3.4./connections diagram Section 13. Screw tight the unit plug with 2 self-tapping screws on the rear panel of the unit.



All voltages on connector socket X5 are safety low voltages and are doubly insulated from the mains. Connections to this socket must not be switched together with dangerous contact voltages.

- ➔ Lock the bayonet catch on the pump after plugging in.

Only PFEIFFER connecting cable should be used for connecting the pump.

### 3.6. Connecting The Venting Valve

- ➔ Connect the venting valve to connector socket X1 on the rear side of the TCP 015 in accordance with connections diagram Section 3.4./connections diagram PM 041 532 -S, Section 11.

### 3.7. Connecting The Pumping Station Control Unit TCS 015 (optional)

- ➔ Connect the Pumping Station Control Unit TCS 015 in accordance with connections diagram Section 3.4./connections diagram PM 041 532 -S, Section 11.



Only disconnect the plug connector to the Pumping Station Control Unit TCS 015 once the pump is completely at rest and the unit has been disconnected from the mains power supply.

Further notes regarding the connection of Pumping Station Control Unit TCS 015 can be found in the operating instructions for the TCS 015, PM 800 248 BN.

### 3.8. Connecting The Pump Heating Unit

If a heating unit has been fitted to the pump:

- ➔ Connect the heating unit to mating plug X3 in accordance with connections diagram Section 3.4./connections diagram PM 041 532 -S, Section 11.
- ➔ For the ranges 100 and 120 V switch the heating unit resistances in parallel, for the ranges 220-240 V in series.

The maximum pump heating current is 1A.

### 3.9. Connecting The Air Cooling Unit

- ➔ Select the air cooling in accordance with the mains voltage (please see "Accessories").
- ➔ Connect the connecting cable to X2 in accordance with connections diagram PM 041 532 -S.

### 3.10. Connecting The Remote Control Unit

The TCP 015 or the complete pumping station can be remote controlled. The respective contacts are made via z2/TCP 035 Print Module. For the connection description please refer to Section 6.5./TCP 035.

### 3.11. Connecting The Backing Pump With Intermittent Operations

It is possible to operate the backing pump without a pumping station control unit by employing a Diaphragm Pump MVP 012 with semi-conductor relay.

Switch S14 is used to select either non-stop operations (ON) or intermittent operations (OFF). Please refer to Section 7.6.

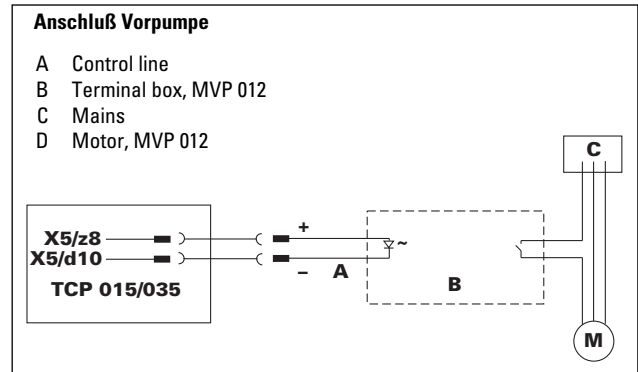

If Pumping Station Control Unit TCS 015 is in use, the connections are made in accordance with connections diagram PM 041 532 -S. The control line is connected to X5/d12. Backing pump operations with X5/z12 as control line are also possible.



Only doubly insulated relays to the mains voltage may be used.

### 3.12. Connecting The Serial Interface

Serial Interface RS 232C is integrated in Print Module TCP 035 as standard and is therefore a component of the TCP 015. For a description of the connection please refer to Section 6.8.



Only safety low voltages (SELV) may be connected to the serial interface plug.

## 4. Operations, TCP 015

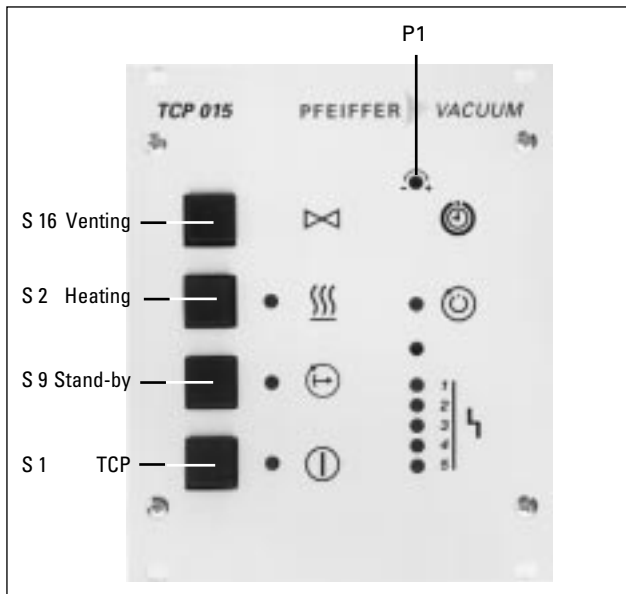

### 4.1. Switching ON The Electronic Drive Unit And The Turbopump

- ➔ Switch on the Electronic Drive Unit TCP 015 with mains switch S1.

### Self-Testing

After the TCP 015 is switched on, the integrated TCP 035 carries out a self-test in respect of the most important functions. The functions referred to in Section 9. and those designated with an "S" are tested and possible malfunctions displayed coded with the aid of LEDs H2-H5 (please refer to the table in Section 8.4.). If in addition H1 illuminates the TCP will remain inoperable.

### Start-Up

Once the self-test has been successfully completed the pump starts up during which the maximum current is 2.2 A. Potentiometer P1 can be used to pre-select a time of 8-60 min within which the pump must have attained 750 Hz. If the frequency is not attained within this time or if the rotation speed falls below this frequency after this time elapses **E011** is displayed.

### Normal Operations

Once the pump has attained its nominal rotation speed the rotation speed will be maintained at a constant  $\pm 2\%$

### 4.2. Switching "Stand-By" ON And OFF

- ➔ Switch stand-by with S9 on the front panel.

The pump runs at 66% of its nominal rotation speed. This operations mode can then be selected when the pressure in the vacuum chamber is sufficiently low, e.g. during breaks in operations. Stand-by mode helps to protect the pump bearing..

### 4.3. Turbopump Venting

- ➔ When the turbopump has been switched off via mains switch S1, vent the pump by depressing the venting switch (the venting valve must be fitted). If the rotation speed falls below 50% of the nominal value venting proceeds automatically.

### 4.4. Switching The Heating Unit ON And OFF

- ➔ Pre-select turbopump heating with switch S2.
- If the turbopump rotation speed exceeds the switchpoint of 750 Hz the heating switches on and LED H7 illuminates.
- ➔ Switch off the pump heating via switch S2.

### 4.5. Operations Messages

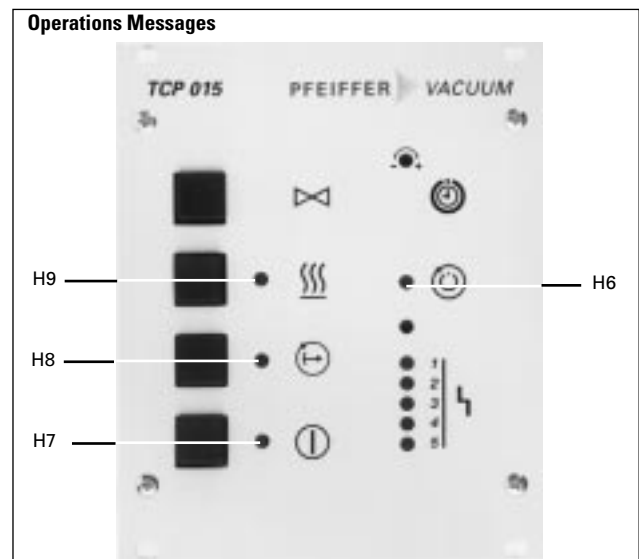

- H6 LED rotation speed switchpoint attained
- H7 LED TCP "ON"
- H8 LED stand-by "ON"
- H9 LED heating "ON"

### 4.6. Use Of The Remote Control Unit

The pump or the pumping station can be remote operated via the Print Module TCP 035. For the procedure please refer to Section 6.6.



## 4.7. Reset

If the TCP 015 identifies an error which is displayed by LED H1 the motor current is switched off.

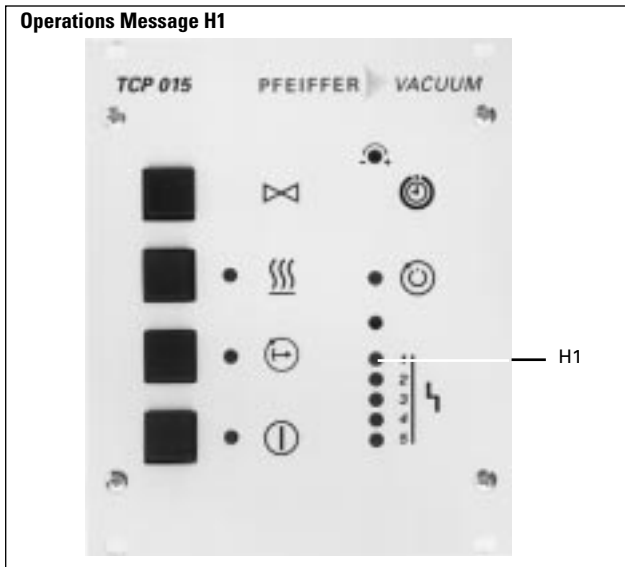

Once the error has been eliminated the pump does not restart automatically. The reset which is necessary is carried out as follows:

- Switch off S1 for a time of > 5 seconds.
- Remote input "Error Reset" (X5/b6).
- Transmission of the respective command via Serial Interface RS 232 C.

## 4.8. The Serial Interface

Electronic Drive Unit TCP 015 is fitted with Serial Interface RS 232 C as standard.

Serial Interface description: Please see disk PM 800 424 BN.

## 4.9. Operations With The Backing Pump

Backing pumps are switched on and off (S1) together with the turbopump where they are connected directly, via the TCS 015 or via a semiconductor relay. In the event of a malfunction, the backing pump is also switched off and a malfunction signal (H1) is triggered.

### Interval Operations

A connected backing pump is switched on and off in dependence on the power take-up of the turbopump. The lower switchpoint<sup>1)</sup> at which the backing pump switches on is fixed. The upper switchpoint<sup>2)</sup> can be varied via potentiometer P2 which is accessible on the front panel and which allows individual settings for any arrangement. Turning P2 to the left means an increase and to the right a decrease of the pressure at which the pump should switch on. P2 has been set to a power of 20 Watt in the works and this corresponds to a pressure of approximately 4 mbar.

<sup>1)</sup> lower switchpoint = high forevacuum pressure

<sup>2)</sup> upper switchpoint = low forevacuum pressure

The adjustment of the upper switchpoint should be carried out with the help of a fore-vacuum pressure gauge.

Switching off follows after a delay time of 10 seconds. If the upper switchpoint is exceeded, switching on follows after 20 seconds.

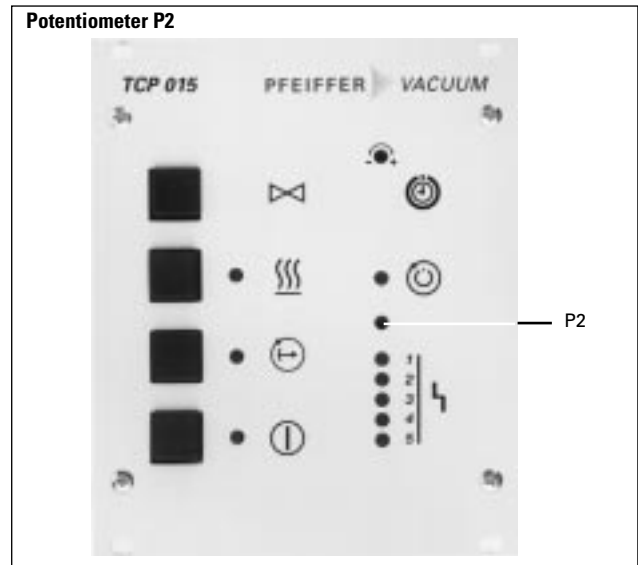

### Non-Stop Operations

- ➔ Turn potentiometer P2 to the right up to the stop point.
- Interval operations is switched off and the backing pump operates in non-stop mode.

## 4.10. Operations With Pumping Station Control Unit TCS 015

The TCS 015 is provided for operations with pumping station control. The TCS 015 controls and monitors the backing pump and the fore-vacuum safety valve.

Connection TCS 015: Please refer to Operating Instructions PM 800 248 BN.

## 4.11. Switching OFF

The pump can be switched off:

- ➔ By activating switch S1.
- > The voltage supply is disrupted.

## 5. Understanding The Electronic Drive Unit TCP 035

### 5.1. Product Description

The Electronic Drive Unit TCP 035 has been designed as an integratable component and serves to drive and monitor PFEIFFER turbomolecular pumps with single phase direct current motors (1500 Hz).

The delivery consignment encompasses:

- Print Module TCP 035

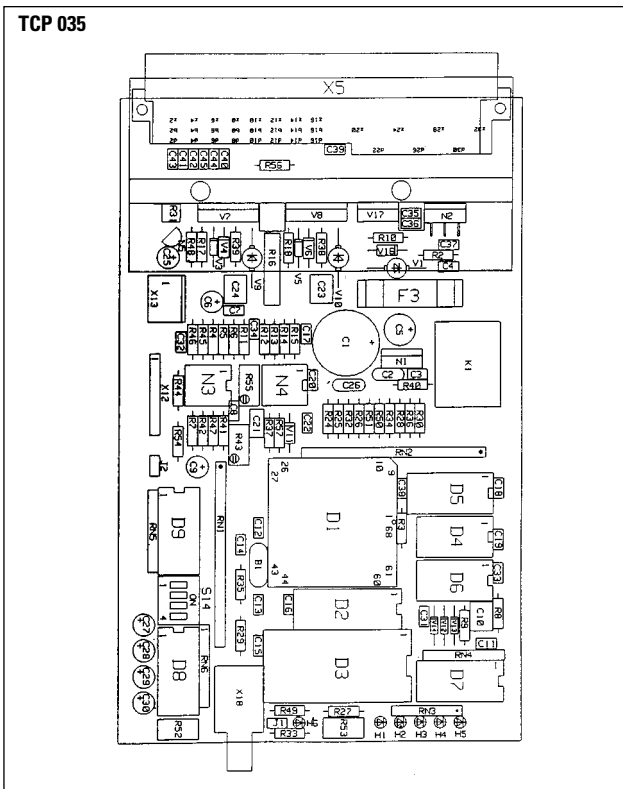

The electronic drive unit contains the following functional features:

- Motor drive
- Monitoring and process control
- Illuminating diode display with information concerning the operational status of the pump
- Serial Interface RS 232/ RS485.

#### Connection Options For:

- Remote control,
- Host computer via Serial Interface RS 485/RS 232.

#### Proper Use:

- The Electronic Drive Unit TCP 035 has been designed as an integratable component and may only be used to drive and monitor PFEIFFER turbomolecular pumps with single phase motors.
- The operations unit TCP- turbopump may only be operated together with a backing pump.
- Instructions concerning installation, start-up, operating and maintenance must be observed.

#### Improper Use:

Improper is:

- Uses not covered above, and, in particular,
  - Connection to pumps and units which is not permitted in their operating instructions.
  - Connection to dangerous to touch voltages.

Improper use will cause any rights regarding liability and guarantees to be forfeited.

#### Safety Instructions

- The operations voltage for the TCP 035 must be safety low voltage (SELV; 26-42 V=).
- Guarantees apply only to units which are fitted in a condition which has not in any way been altered.

## 6. Installation, TCP 035

### 6.1. Preparations For Installation



Unauthorised modifications or alterations to the Display Control Unit are not allowed. The unit must be fitted in a housing taking account of the ambient conditions (see Section 10., "Technical Data").

Electrical connection: Please refer to connections diagram PM 041 532 -S, Section 11. and pin arrangement diagram PM 031 403 -S, Section 12.

- ➔ Secure mating plug X5 against falling out.

### 6.2. Fitting The Unit Into A Rack

The Electronic Drive Unit TCP 035 has been designed to be fitted into a rack. The following should be taken account of when fitting:

- ➔ On installation the TCP should be insulated.
- ➔ Ensure safe distance from the influence of extraneous voltages.
- ➔ Exclude influence of interference frequencies.
- ➔ Provide adequate air circulation (cooling). Fit the unit vertically and, if possible, mount a cooling unit on the side panel.

The ambient temperature in the rack casing should not exceed 40 °C.

### 6.3. Connecting The Operations Voltage

The TCP 035 has been designed to operate on a voltage of 26-42V. This is applied to X5/z28 and X5/z32 and joined with jumper J2 on UB\*.

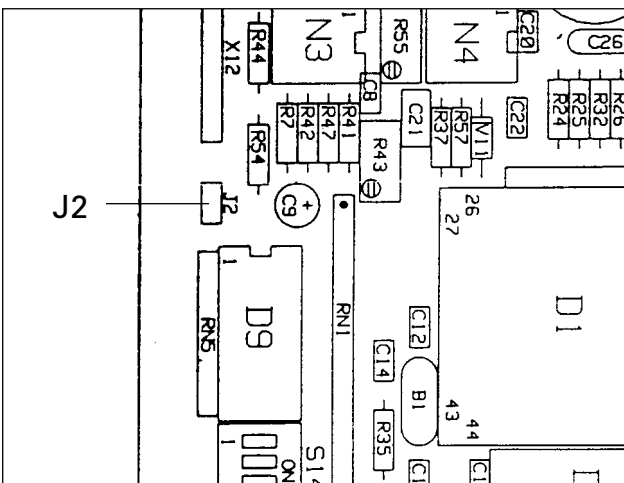

The supply voltage must be safety low voltage (SELV). If this is not available, only low voltage which is generated by an isolating transformer in accordance with EN 60742 may be used. In such cases:

- ➔ Earth the pump at the earthing screw provided.

When switching off the pump, the pump motor acts as a generator and feeds direct voltage back to the electronic drive unit giving the impression that the unit is still switched on. This can be prevented by taking the following action:

- ➔ Connect a diode from X5/z28 to X5/b12 and remove jumper J2 from the print (please see "Layout" in Section 5.1.).

Separate supply from the power unit and control electronics can also be used. In such cases:

- ➔ Feed separated rectified current UB\* of 16-42 V between X5/z2 (-) and X5/b12 (+) and remove jumper J2.

## 6.4. Connecting The Turbopump



Only disconnect the plug connector to the electronic drive unit once the pump is completely at rest and the electronic drive unit has been disconnected from the mains power supply.

- ➔ Connect the turbomolecular pump with connecting cable PM 031 177 -X to connector socket X5 as per the connections diagram in Section 3.4. If no safety low voltages are being used the pump must be earthed separately.
- ➔ Secure the plug against falling out.
- ➔ Lock the bayonet catch on the pump after plugging in.

Only PFEIFFER connecting cable should be used for connecting the pump.

## 6.5. Connecting The Remote Control

The TCP 035 or the complete pumping station can be remote controlled.



For remote control purposes only connections to safety low voltage (SELV) may be made.

### Remote Control Inputs

The following functions can be switched by connecting the contacts with z2 (0 V):

- b4: Heating ON (only with the TCP 015)
- z4: Pumping station OFF (switches off the current of the turbomolecular pump and, if connected, the backing pump). This status can only be revoked by closing the switch "Error Reset" (b6) for a short time.
- z6: Switch turbopump current OFF
- d4: Stand-by
- z14: Venting the pump with fitted Venting Valve TSF 012; also with switched on TCP.

### Remote Control Outputs

- b10: "Open collector", output switches at stand-by to "low".
- z12: "Open collector", output switches with an error to "low" (H1 illuminates).
- z12: "Open collector", output switches if the rotation speed switchpoint is exceeded to "low".
- d8: 0-10 V = 0 - 2,5 A motor current
- b8: 0-10 V = 0 - 1500 Hz rotation speed.

## 6.6. The Relay Output

Relay K1 switches in over and above the rotation speed switchpoint. Connections to X5/d26/d30. The relay can be used for switching touchable dangerous voltages.

- ➔ Observe the instructions regarding double insulation to all other connections on the unit.

## 6.7. Connecting The Backing Pump

It is possible to operate the backing pump without a pumping station control unit by employing a Diaphragm Pump MVP 012 with semi-conductor relay.

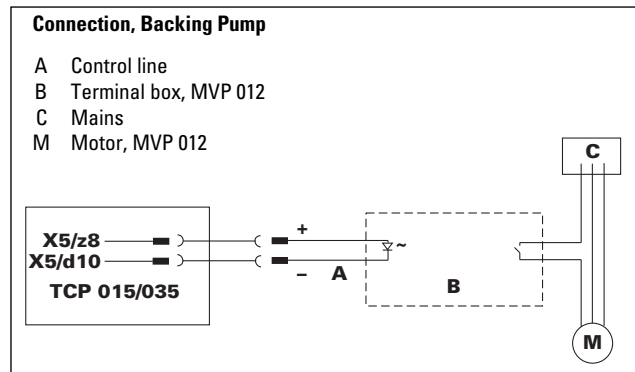

## 6.8. Connecting The Serial Interface

The Electronic Drive Unit TCP 035 is equipped with Serial Interface RS 232 C. This serial interface enables queries to be made regarding the operational status and parameters in the TCP to be altered.

- ➔ Serial interface connection to plug X18 on the Print Module and to the pump plug on X5/b2-d2-z2.

Connection to the computer is made in accordance with the pin arrangement diagram in Section 12.

Serial interface description: Please refer to Operating Instructions PM 800 424 BN.



Only safety low voltages (SELV) may be connected to the serial interface plug.

## 7. Operations, TCP 035

### 7.1. Switching ON The Electronic Drive Unit And The Turbopump

- ➔ Switch on the Electronic Drive Unit TCP 035 with mains switch S1. Please also refer to the pin arrangement diagram in Section 12.

### 7.2. Self-Testing

After the TCP 035 is switched on, a self-test in respect of the most important functions is carried out. The functions referred to in Section 9 and those designated with an "S" are tested and possible malfunctions displayed coded with the aid of LEDs H2-H5. If in addition H1 illuminates the TCP will remain inoperable.

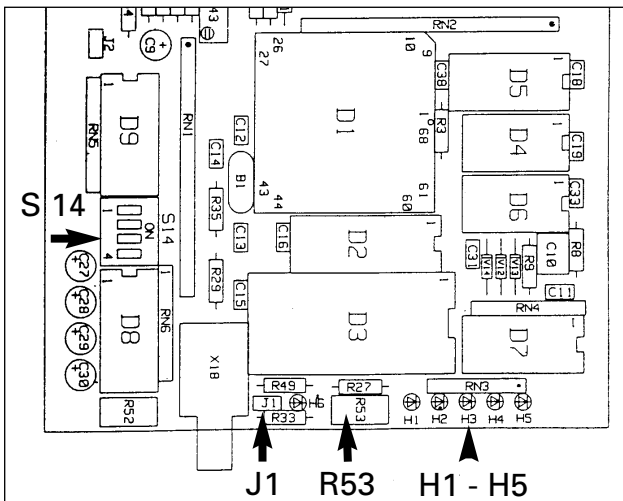

### 7.3. Turbopump Start-Up

Once the self-test has been successfully completed the pump starts up during which the maximum current is 2.2 A. Potentiometer P1 can be used to pre-select a time of 8-60 min within which the pump must have attained 750 Hz. If the frequency is not attained within this time or if the rotation speed falls below this frequency after this time elapses >E011< is displayed.

#### Normal Turbopump Operations

Once the pump has attained its nominal rotation speed the rotation speed will be maintained at a constant  $\pm 2\%$ .

### 7.4. Switching "Stand-By" ON And OFF

This operations mode can then be selected when the pressure in the vacuum chamber is sufficiently low, e.g. during breaks in operations. Stand-by mode helps to protect the pump bearing.

#### Stand-by "ON" (Rotation Speed = 1000 Hz)

- ➔ Connect remote control input X5/d4 with X5/z2 (0 V) by means of an external switch.

#### Stand-by "OFF" (Rotation Speed = 1500 Hz)

- ➔ Open remote control input X5/d4-z2.

### 7.5. Operations With Motor Current Monitoring

For certain pump processes the motor current is a criterion for the high vacuum pressure. However, account must be taken of the fact that the current in high vacuum operations varies between 0.3 and 0.6A from pump to pump. In addition, the current take-up depends on the size of the backing pump. For these reasons it is not possible to state a generally valid relationship between high vacuum pressure and current. This means that this relationship has to be established for each configuration.

Relay K1 closes when the current switchpoint is non-attained. The switchpoint is set with R53 (please see table).

Voltage on tap R53 (V)	0	0,5	1,5	2,0	2,5	3,0	3,5	4,0	4,5	5,0
Current Threshold (A)	0	0,13	0,39	0,51	0,64	0,77	0,9	1,03	1,11	1,27

An additional time delay can be set with S14/4 during which the pump current must always be non-attained (see section 7.6.).

#### "Setting S14"

The function of the start-up time is preserved. If, once the start-up time has elapsed, the pump current exceeds the set current threshold for longer than 1 or 3 minutes both K1 and the pump current is switched off and the error message >E003< appears.

#### Activating Operations Mode "Motor Current Monitoring"

- ➔ Fix jumper J1 onto the two pins next to the LED "H6".

The establishment of the relationship between current and high vacuum pressure has to be ascertained experimentally



Switching over to operations with motor current monitoring may only be performed when the TCP is current-less.

## 7.6. Altering The Pre-Settings (S14)

Various operations modes can be set on the DIL switch S14 (TCP 035):

DIL Switch	Switch Position OFF	Switch Position ON*
S 14/2	Baud rate serial interface 9600 Baud	Baud rate serial interface 4800 Baud
S 14/3	If, after the start-up time has elapsed, the rotation speed switchpoint (750 Hz) is non attained the motor current is switched off and relay K1 opens.	If 750 Hz has been attained the start-up time is set to 0. If 750 Hz is non-attained, the pump is switched off and K1 opens.
S 14/4 Backing pump operations on X5/d10; X5/d12	Intermittent operations	Non-stop operations
S 14/4 Operation with motor-current monitoring	Time delay of the current signal: 60 seconds	Time delay of the current signal: 3 seconds

\* Works setting

## 7.7. Error Reset

If the TCP 035 identifies an error the motor current is switched off. Once the error has been eliminated the pump does not re-start automatically. The reset which is necessary is carried out as follows:

- Connect remote control input “Error Reset”.  
X5/b6 for a time > 1 second < 5 seconds by means of an external switch to X5/z2 (0 V).
- Transmission of the respective command via Serial Interface RS 232 C

## 7.8. Switching The Turbopump ON and OFF

The pump can be switched off:

- ➔ By activating switch S1,
- ➔ With shut-down: With a switch between X5/z6 and X5/z2 (0 V).

## 7.9. The Serial Interface

The Electronic Drive Unit TCP 035 is equipped with Serial Interface RS 232 C. This serial interface enables queries to be made regarding the operational status and parameters (which are described in the various operations modes in Sections 7.5. and 7.6.) in the TCP to be altered.

## 8. What To Do In The Case Of Breakdowns?

### 8.1. The Function Of The Illuminating Diodes

The TCP 035 is equipped with 5 illuminating diodes H1 - H5 which display errors.

The LEDs H2 - H5 display a coded error message. In the event of serious malfunctions H1 also illuminates and the motor current is switched off. In the case of minor malfunctions H1 does not illuminate and the pump continues to operate. The column "Error Type" of the error table shows whether the error has been diagnosed in self-test S, in operations B or in both cases.

Incorrect error displays can arise if the cable from the pump is disconnected during operations. A reset is necessary if the TCP is to be operated again after a breakdown.

### 8.2. Function Test In The Event Of A Malfunction

When malfunctions occur the following should first be checked:

- Voltage connection on the TCP 015,
- Connection TCP 015 - pump,
- Fore-vacuum pressure.

### 8.3. Eliminating Errors

#### Illumination Diode H1 Does Not Illuminate

- ➔ Check switch position of S 8 and/or eliminate the error on the power pack print.
- ➔ Check mains fuse F1. If mains fuse F1 is defect withdraw plug connector X13 and X14 (+ UB and 0 V). Insert new fuses and use a voltmeter (UB = 28 V) to measure the operations voltage UB on measuring points P1 and P2. Switch off mains switch S1 and re-connect X13 and X14.

#### Pump Venting Valve Does Not Close:

- ➔ Check fuse F2.

#### Air Cooling Does Not Function:

- ➔ Check fuse F4.

### 8.4. Error Code Table

Folgende Fehler werden angezeigt:

Error Nr.	LED (illuminates)					Type of Error <sup>1)</sup>	Error Description	Error Elimination
	H1	H2	H3	H4	H5			
E001	•	•				B,S	UB > 43 V	Check operations voltage
E002			•			B,S	UB < 26 V, in operation < 22 V	Check operations voltage
E003	•	•	•			B,S	I operations, current threshold exceeded	-
E004	•	•		•		S	Pump identification resistance R <sub>f</sub> > 2K8	Incorrect pump type
E005	•	•		•		B	Excess temperature, pump	Cool down pump
E006	•		•	•		B	Excess temperature, TCP	Cool down TCP
E007	•	•	•	•		B	Rotor blocked	Pump defect, inform Service
E008	•				•	B	Excess rotation speed	TCP defect, inform Service
E009	•	•			•	B	Excess temperature, transformer	Cool down TCP
E010			•		•	B,S	Turbo OFF	-
E011	•	•	•		•	B	Start-up time elapsed	Repair leak, check backing pump
E012	•			•	•	B	Pumping station malfunction	Check backing pump and water cooling
E013	•	•		•	•	B,S	Watchdog reset	-
E014	•		•	•	•	B,S	Interruption A (X8)	-
E015	•	•	•	•	•	S	Motor or cable malfunction	Check cable
E016		•*				B,S	Keypad lock ON <sup>2)</sup>	-
E017				•	•	B	Pumping station OFF <sup>2)</sup>	-

• LED illuminates  
\* LED flashes

1) B = Operation  
S = Self-test

2) Switching ON/OFF only via the serial interface

## 9. Maintenance, Service

The unit is maintenance-free. Dirt on the front panel can be removed with a damp cloth having first disconnected the unit from the mains power supply.

### Do Make Use Of Our Service Facilities

In the event that repairs are necessary a number of options are available to you to ensure any system down time is kept to a minimum:

- Have the pump repaired on the spot by our PFEIFFER Service Engineers;
- Return the pump to the manufacturer for repairs;
- Replace the unit with an as good as new exchange unit.

Local PFEIFFER representatives can provide full information.

The connections diagram in Section 11. shows the power carrying current paths with their respective operational voltages.



Customers who carry out their own repairs must take account of the possibility that touchable dangerous voltages can be present in the unit. The relevant instructions must be observed when customers carry out their own repair and maintenance work on units which have come into contact with materials which represent a hazard to health.

### Please Note:

Repair orders are carried out according to our general conditions of sale and supply. If repairs are necessary, please send the pump to your nearest PFEIFFER Service Center.

### Contact Addresses And Telephone Hotline

Contact addresses and telephone numbers can be found on the back cover of these operating instructions.

## 10. Technical Data

### 10.1.Data List

Electronic Drive Unit TCP 015		
Connection voltage switchable	V AC V AC	(100 V) 90 - 112 (120 V) 108 - 133 (220 V) 198 - 245 (240 V) 216 - 267
Mains frequency	Hz	50/60
Power take-up, max. With air cooling	VA	110
Output voltage, max.	V	30 - 40 V
Normal operations		
Start-up current	A	2,2
Nominal frequency $\pm 2\%$ max.	Hz	1500
Stand-by operations		
Start-up current	A	2,2
Nominal frequency $\pm 2\%$ max.	Hz	1000
Contact load K1		
Ohmic load	A	4
Inductive load	A	2 <sup>1)</sup>
Switching voltage, max. VDC	VAC 30	265
Analog outputs:		
Rotation speed	10 V = 1500 Hz $\pm 2\%$	
Current	10 V = 2,5 A $\pm 5\%$	
BLoad carrying capacity of the 0-10 V outputs	mA	5
Start-up time	min	8 - 60
Works setting	min	8
Rotation speed switchpoint	Hz	750
Permissible ambient temperature	°C	0 - 40
Cable length Pump - TCP	m	3
Dimensions, front panel	mm	128,5x106,3
Insertion length	mm	227
Weight	kg	2,7

<sup>1)</sup> with  $\cos \phi = 0,5$

### 10.2.Dimensions

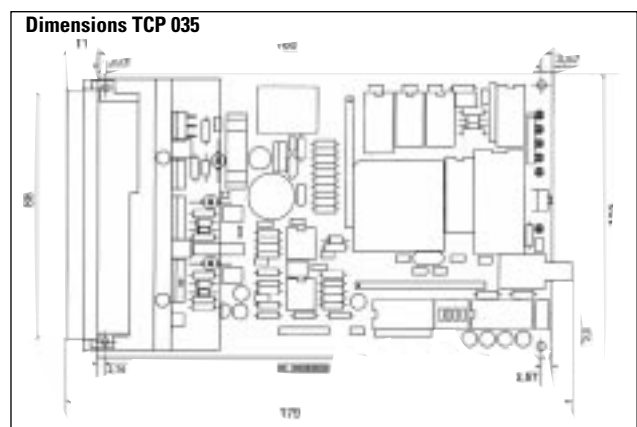
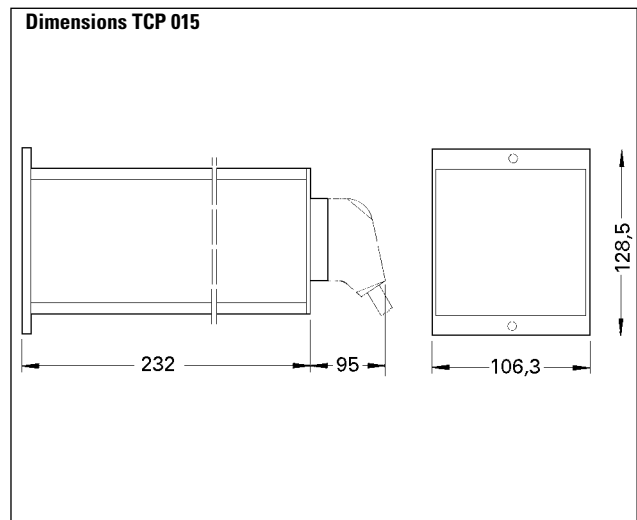



# 11. Connections Diagram

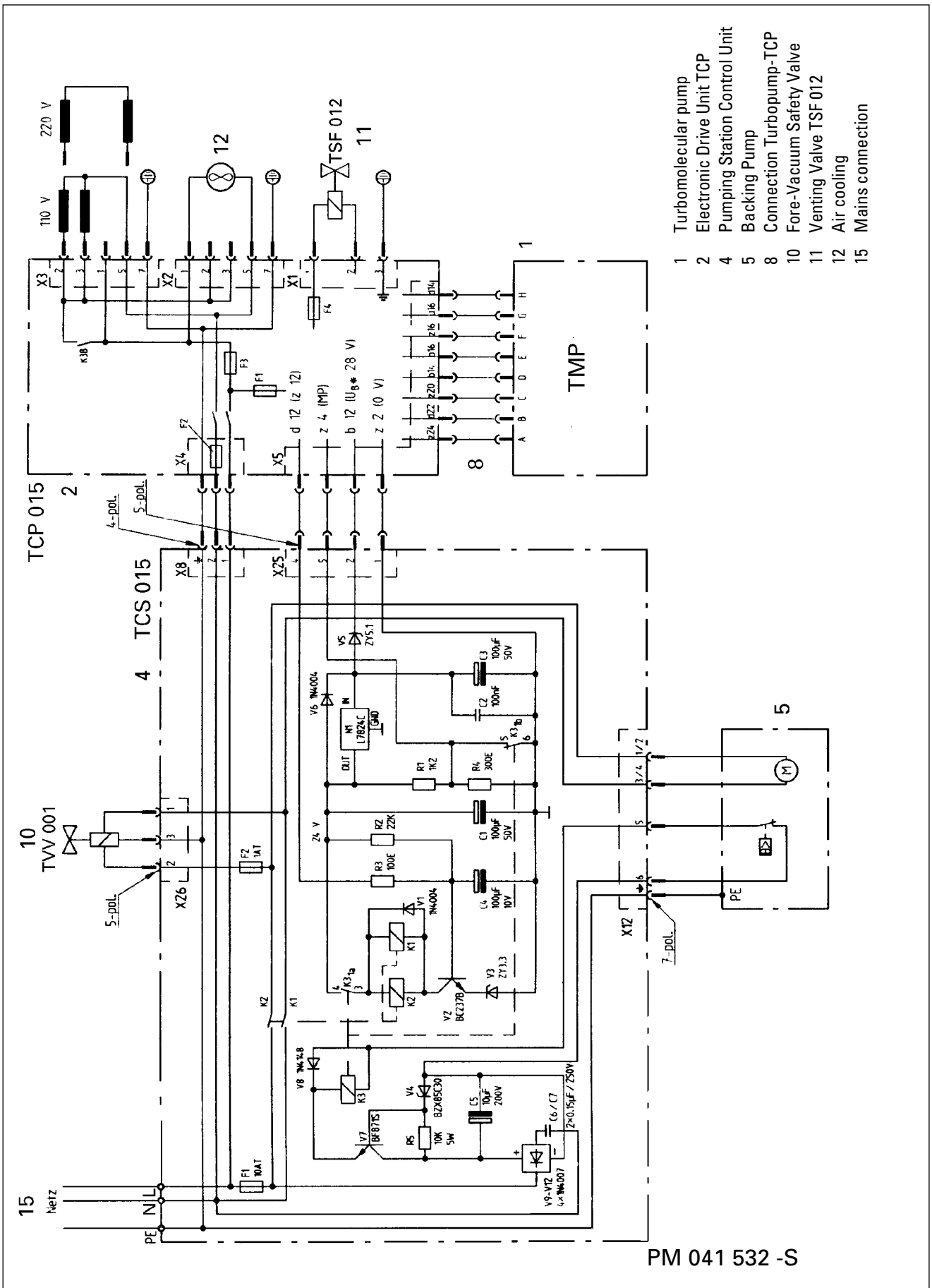

- 1 Turbomolecular pump
- 2 Electronic Drive Unit TCP
- 4 Pumping Station Control Unit
- 5 Backing Pump
- 8 Connection Turbopump-TCP
- 10 Fore-Vacuum Safety Valve
- 11 Venting Valve TSF 012
- 12 Air cooling
- 15 Mains connection

PM 041 532 - S

# 12. Pin Arrangement

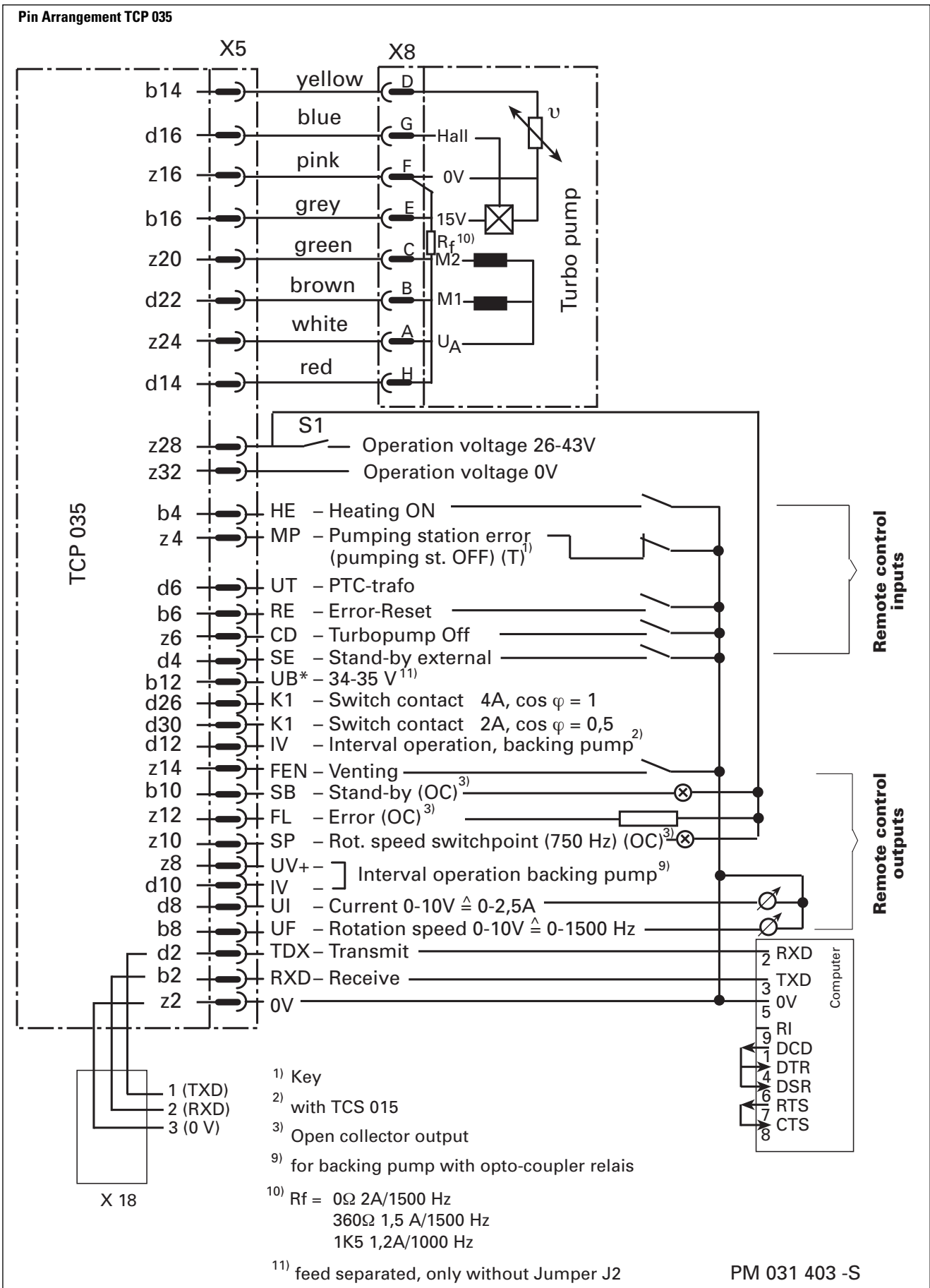

## 13. Spare Parts

Description	Size	Number	Operating Instructions	Order Quantity	Comments
Fuses F1	2 AT	P 4666 442			
Fuses F2, F3	1 AT	P 4666 436			
Fuses F4	0,2 AT	P 4666422			

## 14. Accessories

Description	Size	Number	Operating Instructions	Order Quantity/ Comments
Venting Valve TSF 012*	DN 10-ISO KF	PM Z01 105		
Counter 2002		PM C00 125		
Mains cable		P4564 309ZA		
Measuring and testing adapter		PM 031 522 -U		
<p><i>*With regard to pump types TPH 035 and TPD 020 without special venting connection it is recommended that the venting valve be fitted to the high vacuum side.</i></p>				

⇨ **DE, AT**

**Herstellereklärung im Sinne folgender EU-Richtlinien:**

- **Maschinen 89/392/EWG**
- **Elektromagnetische Verträglichkeit 89/336/EWG**
- **Niederspannung 73/23/EWG**

Hiermit erklären wir, daß das unten aufgeführte Produkt zum Einbau in eine Maschine bestimmt ist und daß deren Inbetriebnahme so lange untersagt ist, bis festgestellt wurde, daß das Endprodukt den Bestimmungen der EU-Richtlinie 89/392/EWG, Anhang II B entspricht.

Wir bestätigen Konformität mit der EU-Richtlinie über elektromagnetische Verträglichkeit 89/336/EWG und der EU-Niederspannungsrichtlinie 73/23/EWG.

Die angewandten Richtlinien, harmonisierten Normen, nationalen Normen und Spezifikationen sind unten aufgeführt.

⇨ **GB, IE**

**Manufacturer's declaration pursuant to the following EU directives:**

- **Machinery Directive 89/392/EEC**
- **Electromagnetic Compatibility Directive 89/336/EEC**
- **Low Voltage Directive 73/23/EEC**

We hereby certify that the product specified below is intended for installation in a machine which is forbidden to be put into operation until such time as it has been determined that the end product is in accordance with the provision of EU Directive 89/392/EEC, Annex II B.

We certify conformity with EU Electromagnetic Compatibility Directive 89/336/EEC and EU Low Voltage Directive 73/23/EEC.

The guidelines, harmonized standards, national standards and specifications which have been applied are listed below.

⇨ **BE, FR**

**Déclaration du constructeur conformément aux directives CE suivantes:**

- **directive machine CE 89/392/CEE**
- **directive CE 89/336/CEE concernant la compatibilité électromagnétique**
- **directive CE 73/23/CEE concernant la basse tension**

Nous déclarons par la présente que le produit mentionné ci-dessous est prévu pour le montage sur une machine et que sa mise en service est interdite tant qu'il n'a pas été déterminé que le produit final répond bien aux dispositions de la directive CE 89/392/CEE, appendice II B.

Nous confirmons la conformité du produit avec la directive CE 89/336/CEE concernant la compatibilité électromagnétique et la directive CE 73/23/CEE concernant la basse tension. Les directives appliquées, normes harmonisées et les normes et spécifications nationales appliquées figurent ci-dessous.

⇨ **IT**

**Dichiarazione del costruttore ai sensi delle seguenti direttive UE:**

- **Macchinari 89/392/CEE**
- **Compatibilità elettromagnetica 89/336/CEE**
- **Bassa tensione 73/23/CEE**

Si dichiara che il prodotto qui menzionato è destinato al montaggio in una macchina e che la sua messa in funzione è vietata sin quando non è stato accertato che il prodotto finale non rispetta le disposizioni della direttiva UE 89/392/CEE, Appendice II B.

Attestiamo la conformità con la direttiva UE sulla compatibilità elettromagnetica 89/336/CEE e la direttiva UE sulla bassa tensione 73/23/CEE.

Sono riportate in basso le direttive applicate, le norme standardizzate nonché le norme e le specifiche nazionali utilizzate.

⇨ **ES**

**Declaración del fabricante al tenor de las siguientes Directivas de la UE:**

- **Maquinarias 89/392/MCE**
- **Compatibilidad Electromagnética 89/336/MCE**
- **Baja Tensión 73/23/MCE**

Por la presente declaramos que el producto mencionado más abajo está previsto para ser incorporado en una máquina y que la puesta en servicio de la misma queda prohibida en tanto que no se haya verificado que el producto final concuerda con las disposiciones resultantes de la Directiva 89/392/MCE de la UE, Apéndice II B.

De nuestra parte certificamos la conformidad con la Directiva 89/336/MCE de la UE sobre Compatibilidad Electromagnética y la Directiva 73/23/MCE de la UE sobre Baja Tensión.

Las directivas aplicadas, normas armonizadas y las normas y especificaciones nacionales aplicadas se mencionan abajo.

⇨ **NL**

**Verklaring van de fabrikant in de zin van de volgende EU-richtlijnen:**

- **machinerichtlijn 89/392/EEG**
- **richtlijn over elektromagnetische compatibiliteit 89/336/EEG**
- **richtlijn over laagspanning 73/23/EEG**

Hiermee verklaren wij dat het hieronder genoemde product is bedoeld om te worden ingebouwd in een machine en dat de ingebruikneming hiervan zolang verboden is, totdat is vastgesteld dat het eindproduct voldoet aan de bepalingen van EU-richtlijn 89/392/EEG, appendix II B.

Wij bevestigen de conformiteit met de EU-richtlijn over elektromagnetische compatibiliteit 89/336/EEG en de EEG-richtlijn over laagspanning 73/23/EEG

De toegepaste richtlijnen, geharmoniseerde normen en de toegepaste nationale normen en specificaties zijn hierna aangegeven.

⇨ **DK**

**Producenterklæring i henhold til følgende EU-direktiver:**

- **Maskiner 89/392/EWG**
- **Elektromagnetisk kompatibilitet 89/336/EWG**
- **Lavspænding 73/23/EWG**

Hermed erklærer vi, at det nedenstående produkt er beregnet til indbygning i en maskine og at dennes idriftsættelse er forbudt, indtil det er fastslået, at slutproduktet er i overensstemmelse med EU-direktiv 89/392/EWG tillæg II B.

Vi attesterer konformitet med EU-direktiv vedrørende elektromagnetisk kompatibilitet 89/336/EWG og med EU-lavspændingsdirektiv 73/23/EWG.

De anvendte direktiver, harmoniserede standarder og de anvendte nationale standarder og specifikationer er angivet nedenfor.



**Tillverkarens förklaring enligt följande EG-direktiv:**

- Maskindirektiv 89/392/EEC
- Elektromagnetisk tolerans 89/336/EEC
- Lågspänning 73/23/EEC

Härmed förklarar vi, att den nedan nämnda produkten är avsedd för inmontering i en maskin och att denna maskin inte får tas i drift förrän det har konstaterats, att slutprodukten stämmer överens med EG's direktiv 89/392/EEC, annex II B.

Vi bekräftar konformitet med EG's-direktiv om elektromagnetisk tolerans 89/336/EEC och EG's lågspänningsdirektiv 73/23/EEC.

De riktlinjer, anpassade standarder, nationella standarder och specifikationer som har blivit accepterade, anges här nedan.



**Valmistajan vakuutus seuraavien EU-direktiivien mukaisesti:**

- konedirektiivi 89/392/ETY
- sähkömagneettinen siedettävyyys 89/336/ETY
- pienjännite 73/23/ETY

Vakuutamme täten, että allamainittu tuote on tarkoitettu asennettavaksi koneeseen ja sen käyttöönotto on kielletty kunnes on todettu, että lopullinen tuote vastaa EU-direktiivin 89/392/ETY vaatimuksia.

Vahvistamme vaatimustenmukaisuuden EU-direktiivin sähkömagneettinen siedettävyyys 89/336/ETY ja EU-pienjännitedirektiivin 73/23/ETY kanssa.

Soveltamamme suuntaviitat, harmonisoidut standardit, kansalliset standardit ja rakennemääräykset on luteltu alempana.



**Declaração do fabricante, de acordo com as seguintes Directivas CE:**

- Máquinas, na redacção 89/392/CEE
- Compatibilidade electromagnética, na redacção 89/336/CEE
- Baixa tensão, na redacção 73/23/CEE

Com a presente, declaramos que o produto abaixo indicado se destina à montagem numa máquina e que é proibida a colocação em serviço da mesma antes de se ter declarado, que o produto final está em conformidade com o disposto na Directiva CE, na redacção 89/392/CEE, Apêndice II B.

Certificamos haver conformidade com o disposto na Directiva CE sobre compatibilidade electromagnética, na redacção 89/336/CEE, e o disposto na Directiva CE sobre baixa tensão, na redacção 73/23/CEE.

Abaixo, dá-se indicação das directivas aplicadas, das normas harmonizadas e das normas e especificações aplicadas no respectivo país.



Δήλωση κατασκευαστή κατά το νόημα των εθής οδηγιών της Ε.Ε.:

- περί μηχανών 89/392/Ε.Ο.Κ.
- περί ηλεκτρομαγνητικής συμβατότητας 89/336/Ε.Ο.Κ.
- περί χαμηλής τάσης 73/23/Ε.Ο.Κ.

Με την παρούσα δήλωση βεβαιώνουμε ότι το κατωτέρω αναφερόμενο προϊόν προορίζεται για την προσαρμογή σε μία άλλη μηχανή, και ότι η έναρξη λειτουργίας της απαγορεύεται μέχρις ότου διαπιστωθεί, ότι το συνολικό συγκρότημα ανταποκρίνεται στους ισχύοντες κανονισμούς της οδηγίας της Ε.Ε. 89/392/Ε.Ο.Κ., παράρτημα II Β.

Οι εφαρμοσθέντες κανονισμοί, οι εναρμονισμένες προδιαγραφές και οι εφαρμοσθείσες εθνικές προδιαγραφές και τεχνικές προδιαγραφές αναφέρονται κατωτέρω:

Produkt/Product/Produit/Prodotto/Producta/Produkt/Produkt/Producto/ Προϊόν:

- a) TCP 015
- b) TCP 035

Angewendete Richtlinien, harmonisierte Normen und angewendete, nationale Normen in Sprachen und Spezifikationen:

Guidelines, harmonised standards, national standards in languages and specifications which have been applied:

Les directives appliquées, normes harmonisées et les normes nationales appliquées en langues et spécifications:

Direttive applicate, norme standardizzate e norme nazionali utilizzate in lingue e specifiche:

Directivas aplicadas, normas armonizadas y normas nacionales aplicadas en idiomas y especificaciones:

Toegepaste richtlijnen, geharmoniseerde normen en toegepaste nationale normen met betrekking tot talen en specificaties:

Anvendte direktiver, harmoniserede standarder og de anvendte nationale standarder med sprog og specifikationer:

Directivas aplicadas, normas harmonizadas e normas aplicadas na linguagem e nas especificações do respectivo país:

Εφαρμοσθέντες κανονισμοί, εναρμονισμένες προδιαγραφές και εφαρμοσθείσες εθνικές προδιαγραφές σε γλώσσες και τεχνικές προδιαγραφές:

- a) EN 61010, EN 55011, EN 50081-1, EN 50082-2, IEC 801 1-4, VDE 0843-6
- b) EN 61010

Unterschriften/Signatures/Signature/Firme/Firmas/Handtekening/Underskrifter/Underskrift/ Allekirjoitukset/Assinaturas/ Υπογραφές:

Geschäftsführer (W. Dondorf)  
 Managing Director  
 Gérant d'affaires  
 Gerente  
 Διευθύνων Σύμβουλος

Administrerende Direktør  
 Verkställande Direktör  
 Directeur

## Zentrale/Headquarters

Pfeiffer Vacuum GmbH

Emmeliusstrasse 33  
D-35614 Asslar

Telefon 06441/802-0  
Telefax 06441/802-202  
Hotline 06441/802-333  
Internet:

<http://www.pfeiffer-vacuum.de>

### Argentina

ARO S.A., Casilla de Correo 4890,  
1000 Buenos Aires, telephone 0054 / 1 331 3918,  
telefax 0054 / 1 331 3572

### Australia

Balzers Australia Pty. Ltd., Level 1,  
3, Northcliff Street, Milsons Point, NSW 2061,  
telephone 0061 / 2 9954 1925, telefax 0061 / 2 9954 1939

### Austria

Pfeiffer Vacuum Austria GmbH  
Diefenbachgasse 35, A-1150 Wien,  
telephone 0043 / 1 8941 704, telefax 0043 / 1 8941 707  
Service Hotline: 0043 / 1 8941704

### Belgium / Luxemburg

Pfeiffer Vacuum Belgium N.V./S.A.  
Minervastraat 14, B-1930 Zaventem  
telephone 0032 / 2 725 0525, telefax 0032 / 2 725 0873  
Service Hotline: 0032 / 2 725 3545

### Brazil

Elmi Tec  
Assistencia Técnica e Representação S/C Ltda.  
Rua Bernadino de Compos, 551  
CEP 04620-002 São Paulo, SP - Brasil  
telephone 0055 / 11 532 0740  
telefax 0055 / 11 535 3598

### Chile

BERMAT S.A., Coyancura 2283, piso 6  
Providencia, P.O. Box 9781, Santiago  
telephone 0056 / 2 231 8877,  
telefax 0056 / 2 231 4294

### Colombia

Arotec Colombiana S.A., Carrera 15 No.38-17  
P.O. Box 050 862, Santafe de Bogota / D.C.  
telephone 0057 / 1 288 7799, telefax 0057 / 1 285 3604

### Denmark

Pfeiffer Vacuum Scandinavia AB, Vesterengen 2,  
DK-2630 Taastrup, telephone 0045 / 43 52 38 00,  
telefax 0045 / 43 52 38 50

### France

Pfeiffer Vacuum France SAS  
45, rue Senouque, BP 139 F-78531 BUC Cedex  
telephone 0033 / (0)1 30 83 04 00,  
telefax 0033 / (0)1 30 83 04 04

### Germany

Pfeiffer Vacuum Vertriebs GmbH,  
Emmeliusstrasse 33, D-35614 Asslar  
telephone 0049 / 6441 802 400  
telefax 0049 / 6441 802 399  
Service Hotline: 0049 / 6441 802 333

### Great Britain

Pfeiffer Vacuum Ltd.  
Bradbourne Drive, Tilbrook,  
Milton Keynes, MK7 8AZ, United Kingdom  
telephone 0044 / 1 908 373 333  
telefax 0044 / 1 908 377 776

### Greece

Analytical Instruments S.A., 1 Mantzarou St.,  
GR-15451 Athens,  
telephone 0030 / 1 674 8973, telefax 0030 / 1 674 8978

### India

Pfeiffer Vacuum India Ltd.  
25-E Nicholson Road, Tarbund  
Secunderabad 500 009,  
telephone 0091 / 40 775 0014, telefax 0091 / 40 775 7774

### Israel

Eastronics Ltd., 11 Rozanis Street, P.O. Box 39 300,  
Tel Aviv 61392,  
telephone 00972 / 3 6458 777,  
telefax 00972 / 3 6458 666

### Italy

Pfeiffer Vacuum Italia S.p.a.  
Via San Martino, 44 I-20017 RHO (Milano)  
telephone 0039 / 2 93 99 051, telefax 0039 / 2 93 99 05 33

### Japan

Hakuto Co. Ltd., C.P.O. Box 25,  
Vacuum & Scientific Instruments Division  
Tokyo Central 100-91,  
telephone 0081 / 3 32 258 910,  
telefax 0081 / 3 32 259 009

### Korea

Pfeiffer Vacuum Korea Ltd., 3F Haein Building 453,  
Dokok-Dong, Kang Nam-Ku, Seoul, 135-270  
telephone 0082 / 2 3461 0671,  
telefax 0082 / 2 3461 0676

### Netherlands

Pfeiffer Vacuum Nederland BV  
Veldzicht 30a, NL-3454 PW De Meern,  
telephone 0031 / 30 6666050, telefax 0031 / 30 6662794

### Peru

Ing. E. Brammert S.C.R.L., José Pardo 182,  
Apartado 173, PE-18 Miraflores,  
telephone 0051 / 1 445 8178  
telefax 0051 / 1 445-1931

### Poland

Softrade Sp.z.o.o, ul. Malwowa 35,  
PL-60-175 Poznan, telephone 0048 / 61 8677 168,  
telefax 0048 / 61 8677 111

### Portugal

Unilaser Lda, Taguspark  
Núcleo Central, sala nº 268, Estrada Cacém-  
Porto Salvo, P-2780 Oeiras  
telephone 00351 / 1 421 7733,  
telefax 00351 / 1 421 7744

### Singapore

APP Systems Services Pte. Ltd, 2 Corporation Road  
06-14 Corporation Place, Singapore 618494,  
telephone 0065 / 268 2024, telefax 0065 / 268 6621

### Spain

Tecnovac  
Tecnología de Vacío S.L., Ronda de Poniente, 6 Bajo F  
Centro Empresarial Euronova  
E-28760 Tres Cantos (Madrid)  
telephone 0034 / 91 804 11 34,  
telefax 0034 / 91 804 30 91

### Sweden

Pfeiffer Vacuum Scandinavia AB  
Magasingsgatan 35, Box 10412  
S-43424 Kungsbacka  
telephone 0046 / 300 710 80  
telefax 0046 / 300 172 85  
Service Hotline: 0046 / 300 710 85

### Switzerland

Pfeiffer Vacuum Schweiz S.A.  
Förribuckstraße 30, CH-8005 Zürich  
telephone 0041 / 1 444 2255,  
telefax 0041 / 1 444 2266  
Service Hotline: 0041 / 1 2730119

### South Africa

Labotec Pty Ltd., P.O. Box 6553,  
Halfway House  
1685 Midrand  
telephone 0027 / 11 315 5434  
telefax 0027 / 11 315 5882

### Taiwan

S & T Hitech Ltd. Hsinchu office  
No. 103, Hsien Chen 11th Street, Jubei City,  
HsinChu County, Taiwan, R.O.C.  
(zip/postal code: 302)  
telephone 00886 / 3 554 1020  
telefax 00886 / 3 554 0867

### Thailand

S & T Enterprises (Thailand) Ltd.  
18th Floor, Chokchai Int'l Bldg.  
690 Sukhumvit Road  
Klongton, Klongtoey  
Bangkok 10110  
telephone 00662 / 259 4623  
telefax 00662 / 259 6243

### U.S.A.

Pfeiffer Vacuum Technology, Inc.  
24 Trafalgar Square  
Nashua, NH 03063-1988  
USA  
telephon 001 / 603 578 6500  
telefax 001 / 603 578 6550

### Venezuela

Secotec S.A., Apartado 3452, Caracas 1010-A,  
telephone 0058 / 2 573 8687  
telefax 0058 / 2 573 1932

### Other countries

AVI - Applied Vacuum Industries GmbH  
Leginglenstrasse 17A; CH-7320 Sargans  
Switzerland  
telefon 0041 / 81 710 03 80  
telefax 0041 81 710 03 81

### Scope of represented countries

Armenia, Azerbaijan, Bangladesh, Belarus, Bulgaria,  
Cambodia, Estonia, Georgia, Hong Kong, Kazakhstan,  
Kingdom of Nepal, Kirghizia, Latvia, Lithuania, Maldiva,  
Philippines, P.R. China, Rumania, Russia, Tajikistan,  
Turkmenistan, Ukraine, Uzbekistan, Vietnam

### A.E.M.S.

Advanced Equipment Materials and Systems  
P.O. Box 25  
Föhrenweg 18  
FL-9496 Balzers  
telephon 0041 / 75 380 0550  
telefax 0041 / 75 380 0551

### Scope of represented countries

Bahrain, Egypt, Iraq, Iran, Jordan, Kuwait, Lebanon,  
Lybia, Oman, Pakistan, Saudi-Arabia, Sudan, Syria,  
Turkey, United Arab Emirates, Yemen